

Your Name:	<input type="text"/>
Email:	<input type="text"/>
Phone Number:	<input type="text"/>
Company Name:	<input type="text"/>
Company Address:	<input type="text"/>

What diameter size would you like?

125 x 55 mm <input type="checkbox"/>	96 x 40 mm <input type="checkbox"/>
Other (Please specify) <input type="text"/>	

What bore size would you like?

30 mm <input type="checkbox"/>	1¼ inches <input type="checkbox"/>
Other (Please specify) <input type="text"/>	

Machine details

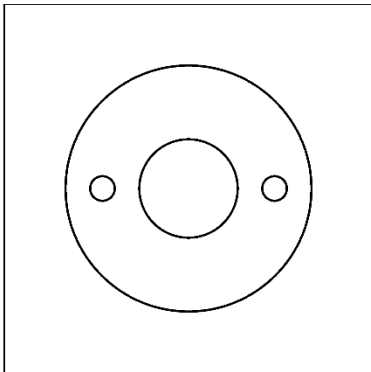
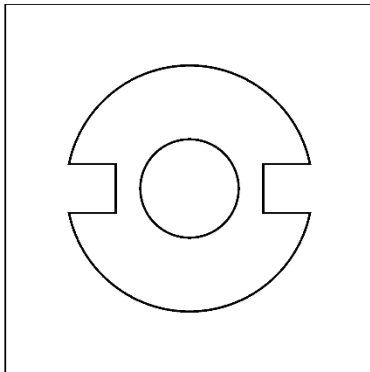
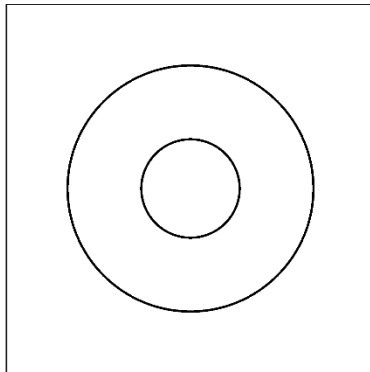
Machine Name & Model	<input type="text"/>	
What size bolt do you use?	<input type="text"/>	
Does your spindle shaft have pinholes, keyways or neither?		
		
Pinholes <input type="checkbox"/>	Keyways <input type="checkbox"/>	Neither <input type="checkbox"/>

If you have pins answer the following:

Are the pinholes, male or female?

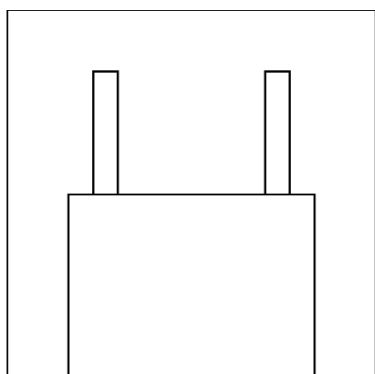

Male

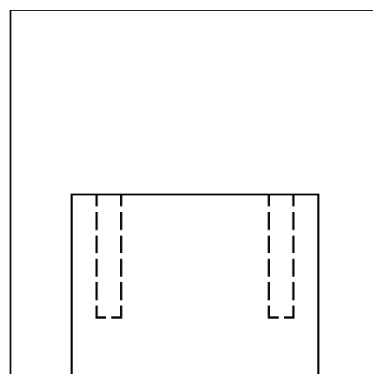

Female

How many pinholes are there?

What is the diameter of the pinhole?

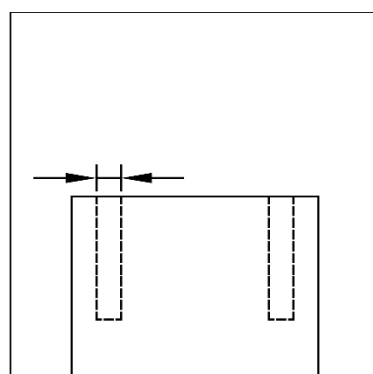
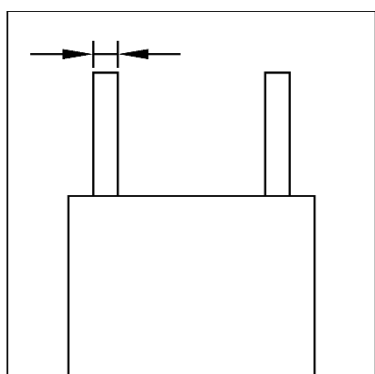

What is the pitch size?
(centre of the pin on one side to the
centre of the pin of the other side)

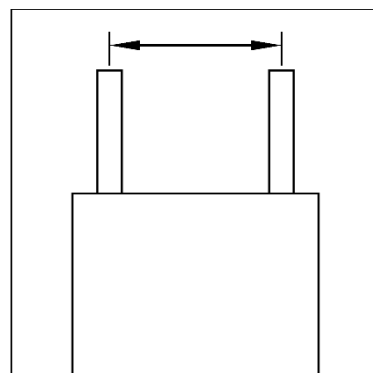
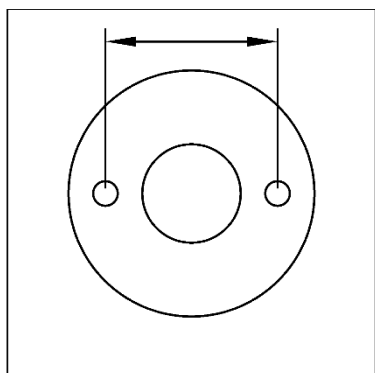

If you have keyways answer the following:

How many keyways are there?

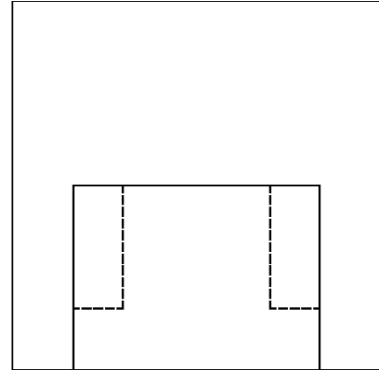
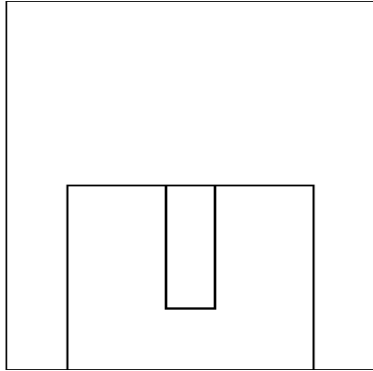

What is the width and length of the keyway?

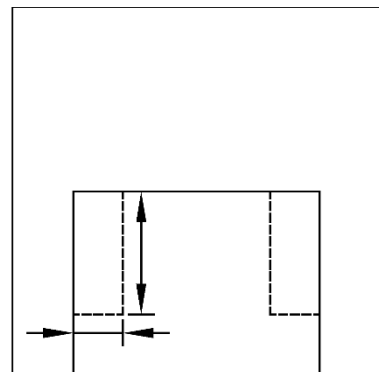
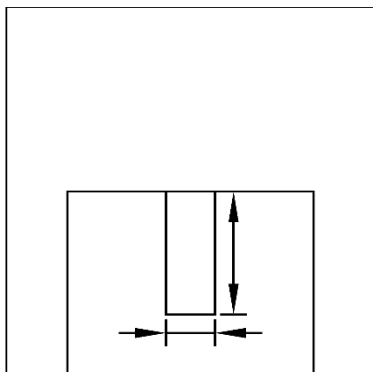

If possible, please provide images of your machine, spindle shaft, and washer, as this will greatly assist us in identifying the most suitable solution.